

HARE & FORBES

MACHINERYHOUSE

Established 1930

Distributors of new & used workshop Equipment

S748A PK-40 RING ROLLER

2006

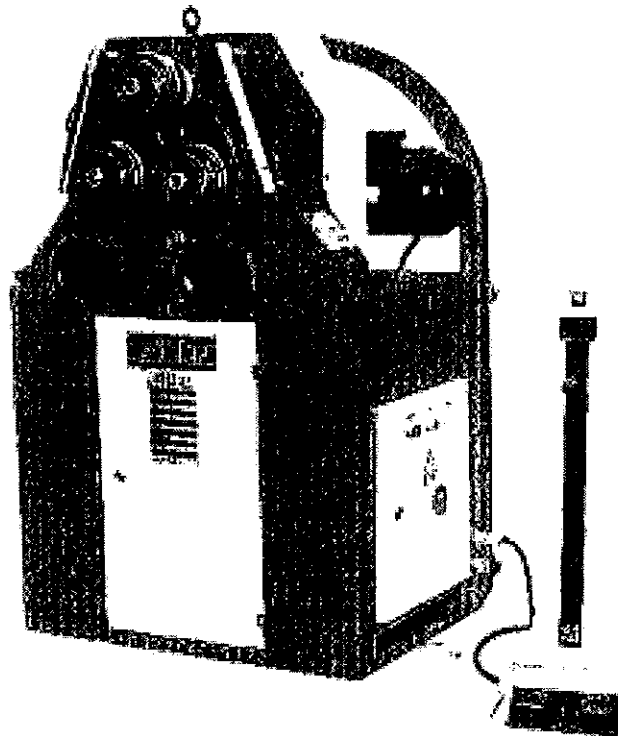



sahinler
METAL MAKİNE ENDÜSTRİ A.Ş.

**USER`S MANUEL
MODEL PK – 40
SECTION BENDING MACHINE**

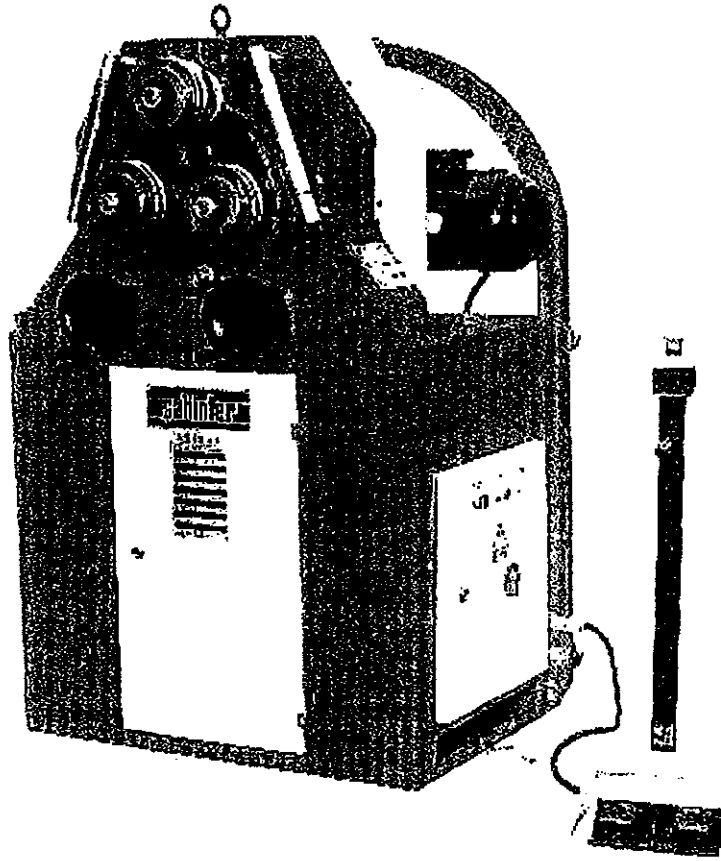

Izmir Yolu 22.km Mümin Gencoğlu Cad. 16285 BURSA / TURKEY

Tel: +90-224-4700158 (6 lines pbx) Fax: +90-224-4700770

Web: www.sahinlermetal.com Email: info@sahinlermetal.com

Spare parts & service: service@sahinlermetal.com



ŞAHİNLER
METAL MAKİNE ENDÜSTRİ A.Ş.



CE DECLARATION

We as

ŞAHİNLER METAL MAKİNE END. A.Ş.
İzmir Yolu 22.km
Mümin Gençoğlu Caddesi
Bursa / TÜRKİYE

confirm that the machine

PK 40

Serial Number :
Production Year :

2006

complies with

EC MACHINES DIRECTIVE 98 / 37 / EWG / CEE
replaced with EC-Directives 91 / 368 / EWG and
93 / 44 / EWG and
93 / 68 / CEE
EC-Low Voltage 73 / 23 / EWG
EC-Noise Level Directives 86 / 188 / EWG

and the machine also harmonized with the standards

DIN EN 60204 Part 1

Name : Mustafa PINARBAŞI
Position : Production Director

BURSA, on...05...TEMMUZ...2006

ŞAHİNLER

Metal Makine Endüstri A.Ş.
Adres: Havacılık Yolu No: 22 - 1129 BURSA
Fabrika: Mümin Gençoğlu Caddesi / Bursa
Tel: 470 00 63 Fax: 470 70 83
Gözetim No: 708 000 4677

INDEX

Page

<i>General Notes</i>	1 – 2
<i>General Warranty Terms</i>	3
<i>General Safety Terms</i>	4
<i>Transporting Lifting and Carrying</i>	5
<i>PK 40's Technical Properties</i>	6
<i>Capacity Chart For PK 40</i>	7
<i>Standard Roller Dimensions For PK 40</i>	8
<i>Foundation and Main Dimensions of The Machine</i>	9 – 10
<i>Operating PK 40 As Horizontal</i>	11
<i>Start – Up Instructions</i>	12 – 13
<i>Operation</i>	14 – 16
<i>Maintenance</i>	17 – 18
<i>Part Lists</i>	19 – 22
<i>Special Accessories For Model PK 40</i>	23
<i>Electric Schemes</i>	



GENERAL NOTES

1. Introduction

Thank you for choosing a Sahinler Sheet / Metal Working Machine. We are proud have you in our long list of satisfied customers all over the world.

This User's Manual is absolutely for your safety and is essential for the machine to have a long production life. As long as you keep up with our Manual you will be able to run your machine smoothly and safely. Keep in mind that the machine is designed absolutely to perform maximum safety and for efficient working.

In this Manual you can find instructions and information about:

- Correct installations of the machine
- Description of the functional parts of the machine
- Set-up and start-up adjustments
- Correct standard and scheduled maintenance
- Simple safety regulations and accident prevention.

Therefore, as far as the user's safety is concerned, in this handbook the possible risks connected with machine operation are pointed out as follows:



ATTENTION: Showing the risks of accident, if instructions are not followed.



WARNING: Showing the probable damages to the machine or equipment, if the instructions are not strictly followed.



NOTE: It gives useful information.

It is certainly necessary that the operator should read and understand all the ATTENTION, WARNING notes specified in this Manual before starting with operation of the machine and before any lubrication or maintenance intervention.

On all steps of installation, operation and maintenance safety must be your first concern for the protection of yourself, other users and the service of the machine.

In case of any failure please first refer to this Manual, and then if a solution cannot be found contact first of all the distributor where you purchased our product. Do not forget to refer to the drawings

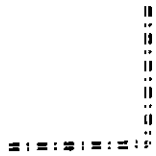

GENERAL WARRANTY TERMS







- *Your machine is covered by manufacturer's guarantee for a period of 12 months from the date of purchase against manufacture defects. The warranty period does not exceed 18 months from the date of delivery from the manufacturer's factory.*
- *Warranty covers only manufacture defective parts and / or components that are reported as "defective" by a Sahinler Technician or the Agent Technician and must be reported to Sahinler in writing by fax or email.*
- *The manufacturer is responsible for the supply of free of charge spares only and cannot be held responsible for loss of work.*
- *Shipping and customs fees for the spare part must be paid by the end-user.*
- *If a technician travel is necessary Sahinler will not charge for labor and workmanship costs but the customer must pay traveling and accommodation charges.*
- *A Warranty claim does not relieve the Customer from payment obligations.*
- *The Customer can not ask or demand any reimbursement of damage nor the Customer will have the right to extend or delay payment obligations nor the cancellation of order and the refunding of damages as the guarantee is given for the defective parts of the machine and not for the job.*



Note: All warranty claims must be applied with the Model, Serial Number and the Manufacture Year of the machine.

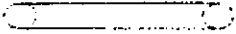
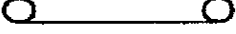
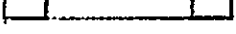
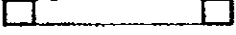
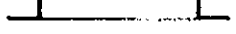
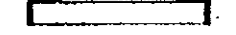
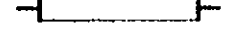
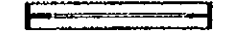

CAPACITY CHART FOR PK 40

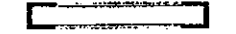
no	profile type	Maximum size	min. int Ø	notes
1		20 x 10 50 x 10	200 600	Standard rolls
2		40 x 5 60 x 20	200 600	Standard rolls
3		25x25 30x30	400 1200	Standard rolls
4		Ø 20 Ø 30	200 500	Optional rolls
5		Ø 50 x 2 Ø 60 x 2	1000 1200	Optional rolls
6		1" x 2,3 1 ½" x 2,3	300 600	Optional rolls
7		40 x 20 x 2,5 50 x 25 x 2,5	800 1000	Optional rolls
8		40 x 40 x 2 45 x 45 x 2,5	800 1200	Optional rolls
9		30 x 30 x 3 50 x 50 x 5	250 800	Optional rolls
10		30 x 30 x 3 45 x 45 x 5	300 800	Optional rolls
11		30 x 4 80 x 9	200 800	Standard rolls
12		30 x 4 70 x 8	300 1000	Standard rolls
13		UPN 50 UPN 60	400 800	Standard rolls
14		UPN 40 UPN 50	400 800	Standard rolls

- > Capacities are given for ST 42 material.
- > We reserve the right to make changes without notices.
- * Optional rolls can be necessary for to bend small diameter



Warning: Do not feed profiles having a higher thickness than specified for the capacity of the machine. Do not feed more than one piece at a time. Do not use the machine for any other scope the one for which it has been designed.



PK 40

TOP ROLLS

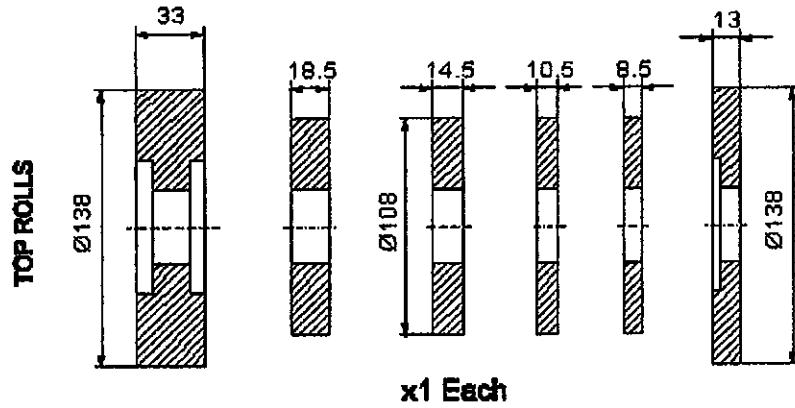

BOTTOM ROLLS

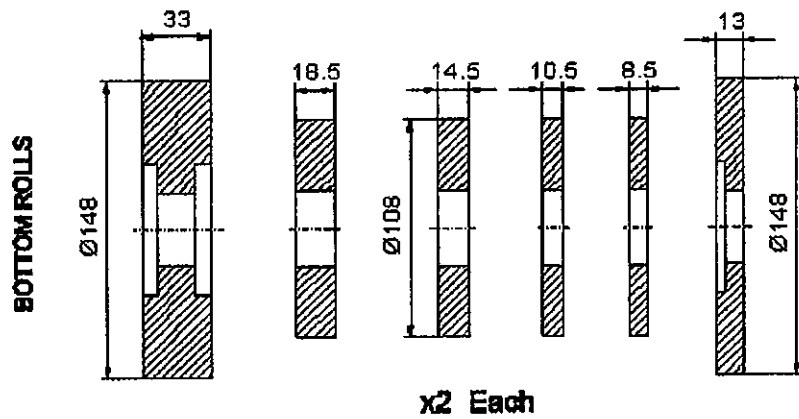

Roll material SAE 1050 hardened to > 56 HRC



Note : As the three have the same and standard sizes, the dimensions given in figure 1 is valid for them all. Also, Special Rollers can be available from ŞAHİNLER METAL MAKİNE ENDÜSTRİ AŞ.



TRANSPORTING, LIFTING AND CARRYING

Before preparing the machine for installation and start-up, an accurate visual control is required in order to detect any possible damages occurred during transporting and handling phases.

Your machine is located on a wooden grid and the package is a waterproof plastic cover.

If one or several parts of the machine have been damaged while shipping, the installation of the machine has to be suspended. ŞAHİNLER METAL MAKİNE ENDÜSTRİ AŞ. has to be informed of the unexpected occurrence straight away.

While lifting take care of these points:

- Always lift and carry the machine from the handles.
- Use a steel rope capable of carrying 800 kg.
- Take precautions for handling and lifting.
- Check if the load is properly balanced by lifting it some centimeters.
- Lift the machine, proceeding with care, without sudden accelerations or quick changes of directions.
- Place the machine where it must be installed, lower the machine slowly till it touches the floor.

Figure 1 shows a way of carrying the machine. You can use a crane with hook or a forklift for handling operation.



Attention: Lifting and carrying operations should be carried out by skilled workers, such as truck operator, crane operator, etc. Also, it is necessary to keep in mind that having large safety margins will provide you efficient working conditions and enable you to take into consideration most of the precautions.

580 kg

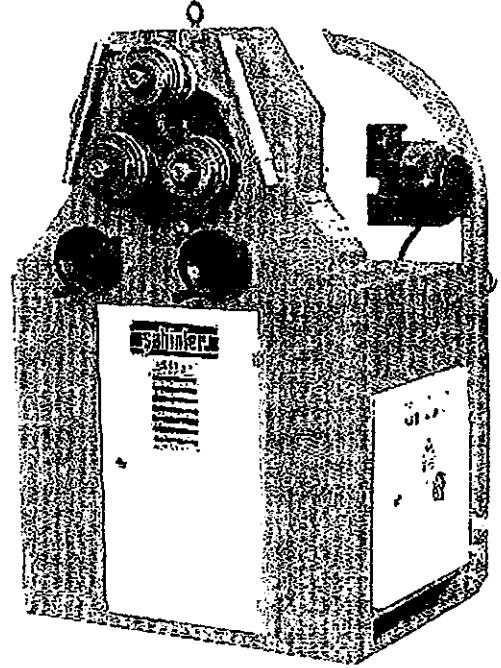
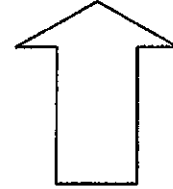

FOUNDATION AND MAIN DIMENSIONS OF THE MACHINE

Main dimensions of the machine of PK 40 is given below.

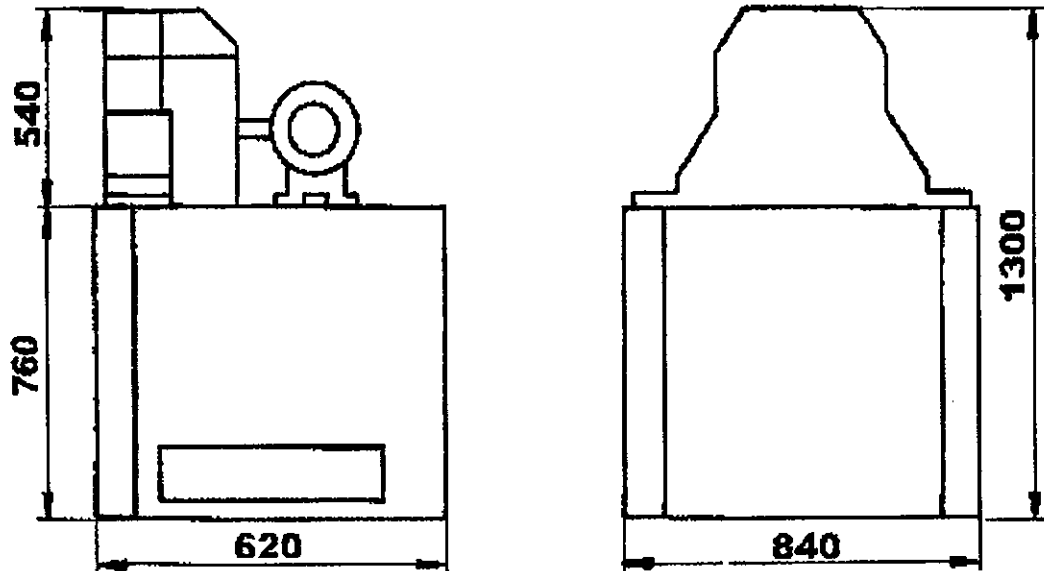

Figure 1



Note: For a correct operation the machine must be placed on a flat, preferably concrete base and even floor. Also, it must perfectly be located horizontally and vertically.



Note: The manufacturer doesn't accept any responsibility for damages due to the non-observance of the above specifications.





Note: Figure 2 shows the area into anyone except for the operator is forbidden to enter. That area is illustrated considering the machine located horizontally. If you operate it vertically, then the borders will be the same. That is, no matter how you located the machine (vertical or horizontal) you should always keep the safety distance of one meter around the machine.

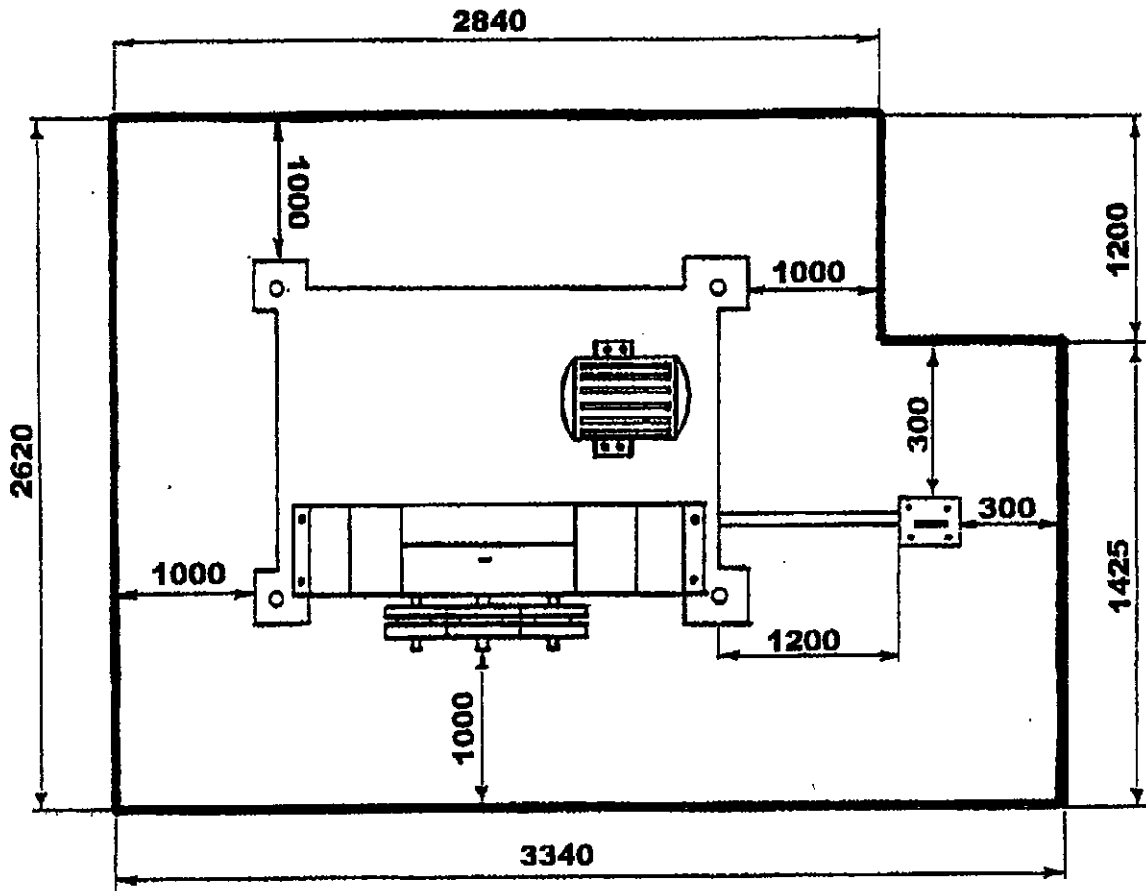
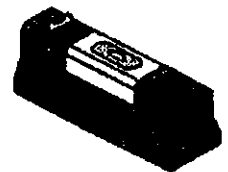

Figure 2



Note: All of machines must adjust goodly and carefully to take smooth working from machine. Machine adjustment must make with water gauge.



OPERATING PK 40 AS HORIZONTAL

Before positioning the machine it is necessary to leave enough working area for the proper bending operations such as: extraction of the cylindrical profile, feeding of the semi product, bending of big diameters.

If you have no alternative to install the machine in a broad area but a low-height area, then there is a solution to this problem as shown in figure 2.

To set the machine horizontally follow these steps:

- Wrap a belt capable of carrying at least 700 kg around the top roll's shaft (shown by ① in fig. 1).
- Lift the machine slowly by means of a forklift or a crane with hook.
- When you are satisfied that you have lifted the machine to the degree that only the corner shown by ② in figure 2 touches to the floor, rotate the machine right slowly with the help of a person so that the mass center of the machine tend to be at right side of that corner.
- After that, slowly lower the machine.

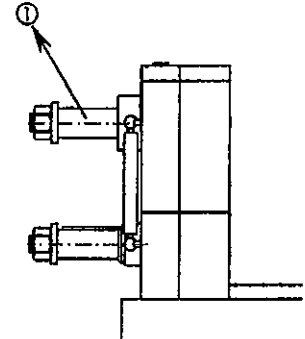

Figure 1



Attention: Do not wrap the belt around the top roll adjustment screw so that it may be bent or its teeth may be damaged.

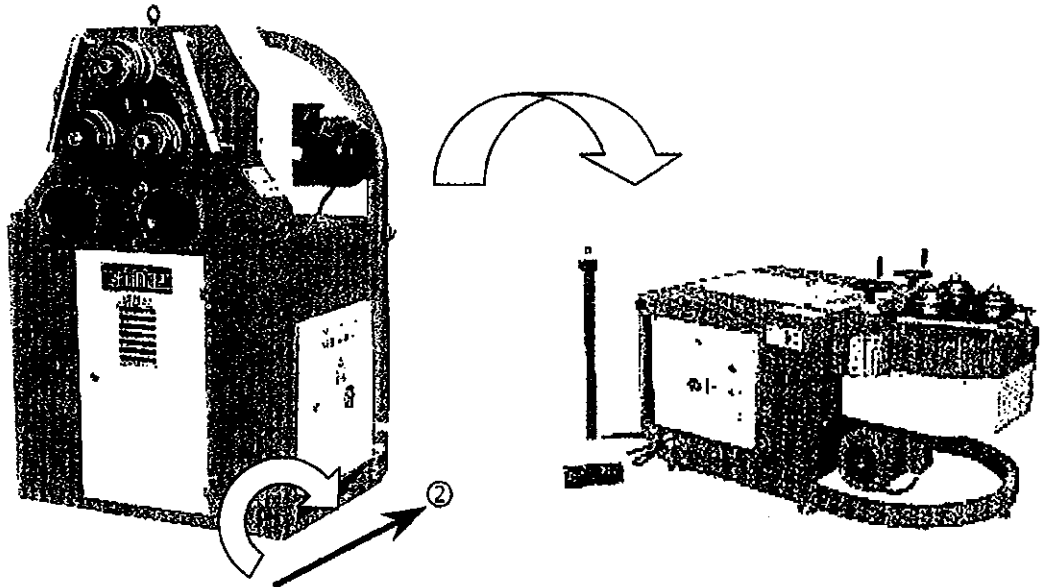

Figure 2

START-UP INSTRUCTIONS

1. Materials and Products

The machine is mainly steel and it is not designed for handling inflammable or detrimental products. It is duty of the customer to check if the processed materials respond to these requirements. Also, it is duty of the customer to check if the processed materials can be dangerous for the operator working nearby.

When selecting the most appropriate operation material you should keep in mind those instructions:

- Material must be clean out of oil and dry (without oil).
- Material diameter must be regular with advised instructions.
- Hardness value must always be same thorough the material.
So, we recommend you to buy certificated steel.
- Parts to be bended should have smooth surface to fulfill the procession correctly and easily.



Note: The thorough cleaning of the rolls is absolutely necessary in order to avoid possible sliding of the profile due to grease residues on the rolls.

2. Electrical Connection

Have a qualified electrician connect the machine to the electric supply. In some cases inverse electrical connection causes the motor burn out. To avoid such an undesirable event, after having connect the machine see that the motor turns to the direction shown by arrow when activated. Or you can check to see if the rolls are rotating to the same direction of the pedals. That is, if the right pedal is pushed, the rolls should rotate right and if the left pedal is pushed, the rolls should rotate left. If the machine does not comply then inverse the electric cables.

3. Electric Box

The PK 40's electric box includes very important controls of the machine and is also connected to the below shown foot pedals. The keys on the electric box are shown and explained here:

1. Electric box lock
2. Main switch
3. Start indicator and pump on indicator
4. Fault on indicator (Thermal overload)
5. Electric on indicator
6. Foot pedal plug-in
7. R-S-T phases plug-in
8. Grounded

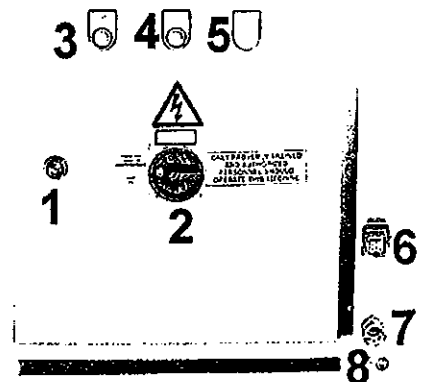

Figure 1



Attention: Electric box shelter must be removed only when the machine is stopped, or during maintenance or adjustment interventions.



Warning: It is suggested to protect the main electric line from possible overloads by means of safety switches.

4. Standard Foot Pedal

The standard foot pedal is equipped with an "emergency button" which instantly stops all the machine activity by disabling the electric supply until released.

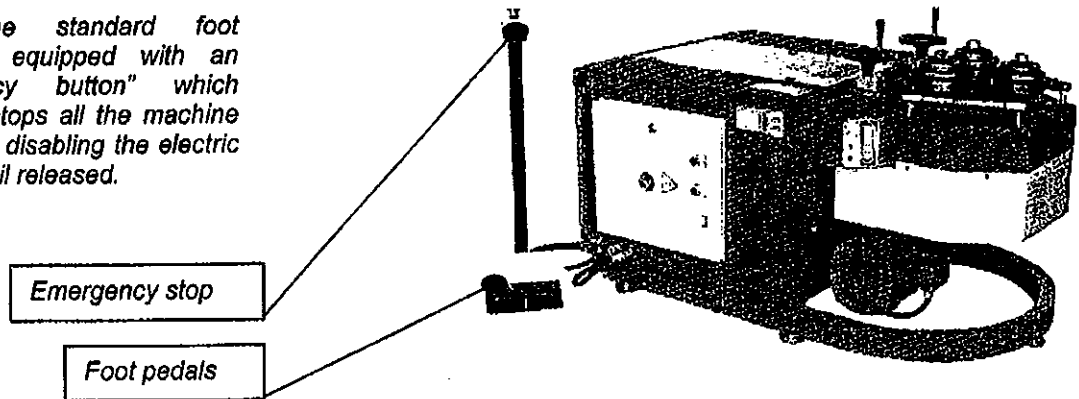

5. Starting The Machine

Following steps will help you start the machine and get ready for the first bending operation. See the sections identifying the necessary switches and buttons.

- Make sure the electrical connection is correct
- Turn on the "main switch"
- You will see electric on "indicator"
- Push "start button"
- Use the "foot pedals" to rotate the rolls
- Make bending use the counters to make radius
- Use the "emergency button" on "foot pedal" to stop the machine
- Turn off the "main switch"

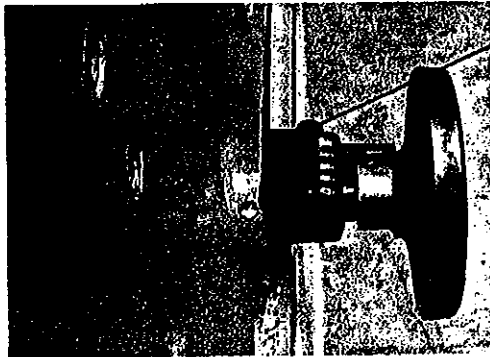

The bottom rolls can be adjusted by two analog counter system. You can see bottom rolls position with analog counter.

6. Basic Operation Terms

The PK 40 has three rolls powered. The all rolls are driven by a motor and a gears to conduct rotation motion from gearbox system when all rolls shaft simultaneously. Top roll can be adjusted by a screw driven system to make the bending in a wide radius range. Therefore, bending operation is simple and smooth however requires experience for efficient working.

Following recommendations will be helpful during operation:

- It is recommended that the user have basic bending information with this kind of machines.
- Making a tight bend in one pass is not possible. So you need several passes before you can achieve a certain radius. Tighter curves and full radius always take a lot of time.
- During operation never wear garments with loose parts, which may be dragged by the machine parts, long loose hair, necklaces, rings etc.
- Use emergency button in case of any emergency.



OPERATION

1. Operating Instructions

Place the material on the rolls flatly as shown in the figure 1. Make sure that material is placed parallel to the ground and touching all three rolls at the same time. This position is called "zero position".

Move the upper roll down like in figure 2 and position it to apply enough force to bend the material. Do not apply force more than necessary. If you apply too much force with the help of moving the upper roll down a lot more than enough, you may deflate the material during bending operation.

Push the speed selector knob to rotate the rolls to which direction you want (look at figure 3). To get desired diameter value make more than one pass by gradually lowering the upper roll after each pass. After a pass if the diameter value is bigger than expected, move the upper roll down to apply more force. If the case is vice versa, then move the upper roll to upside by making use of millimetric ruler.

It is likely that the material will intend to bend right or left because of the existence of bending forces. To prevent this, you must adjust the guide rolls as shown in the figures 4 and 5.

As the guides are adjustable on top and bottom, you can arrange them to the opposite of material directional inclination.

 **Note:** To get a circular profile, side guide joints must be parallel to the machine surface. Otherwise, you just get spiral profiles.

Figure 6 shows bending operations for different kind of sections with special rolls.

In case of bending long materials, material feeder is advised to use in order to keep workpiece parallel to the base ground (see figure 7). This will make easier to bend such workpieces.

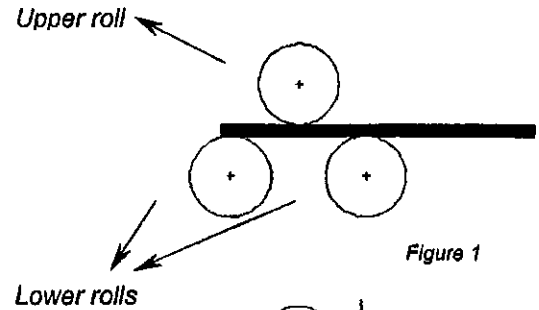

Figure 1

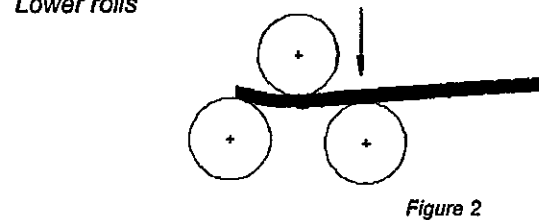

Figure 2

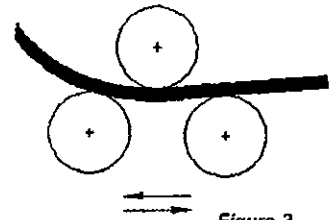

Figure 3

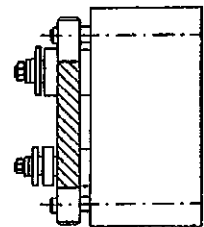

Figure 4

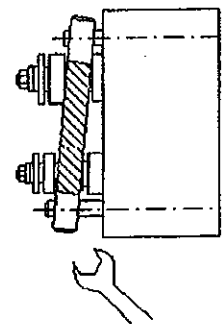

Figure 5

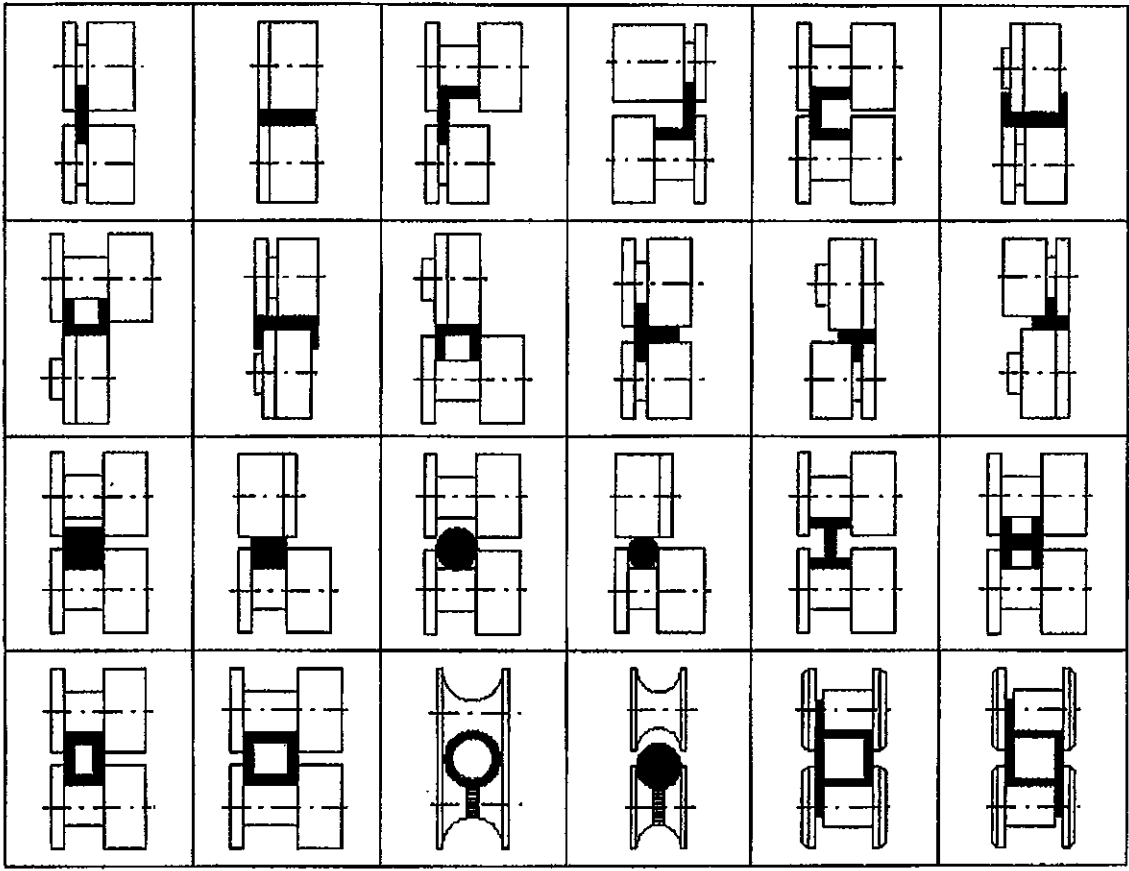

Figure 8

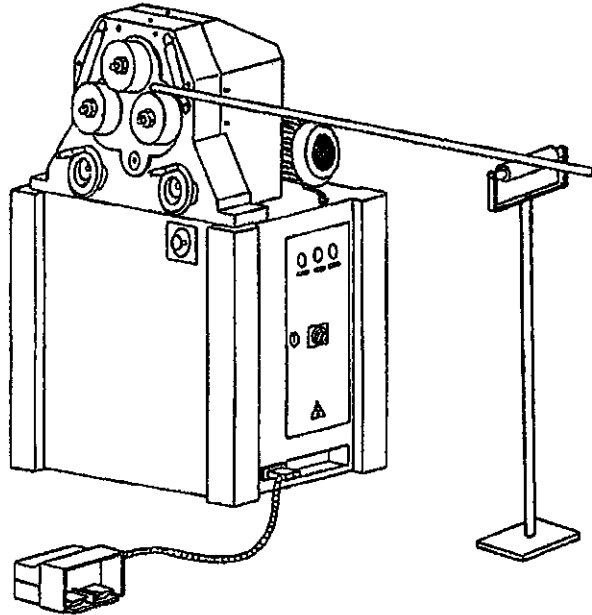

Figure 9



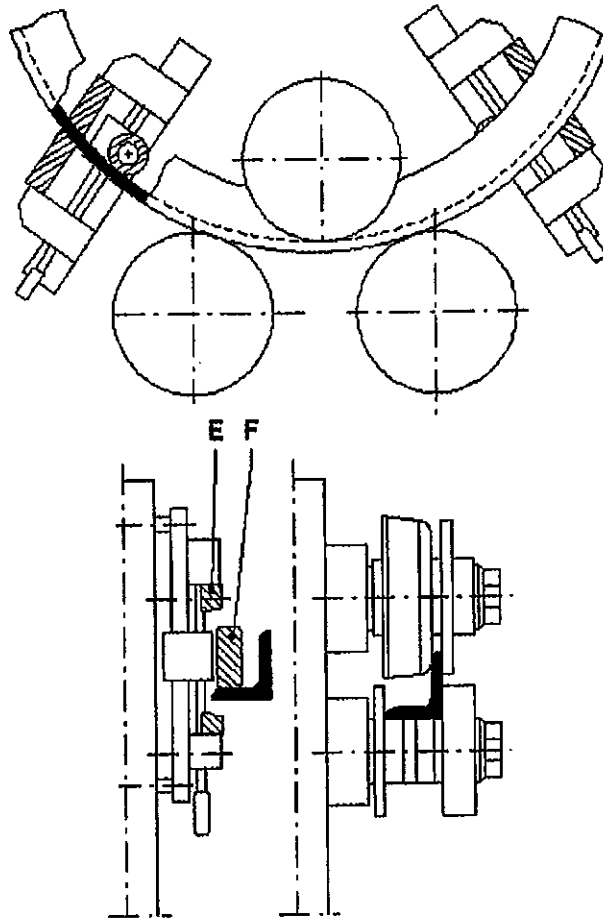

Figure 10

Figure 10 shows the use of "Leg-In Bending Guide Rolls". These guide rolls are special accessory for bending leg-in (angle) material and are available for extra cost. They are adjustable for any size of material and easy to use. Special rolls are recommended for any batch jobs of leg-in or leg-out material. Some of the angle materials can be bent with standard rolls.

2. Operational Hints

- Always clean the rolls and the material of dust, dirt and grease for bending
- If you are bending a pipe do not rotate the pipe while bending
- We advise you to fill the profiles or pipes with sand or any similar material if they have a wall thickness of less than 2 mm
- Do not overload the machine and use special rolls for profiles as well as pipes
- Operate safely keeping in mind the third party people around the machine
- Leave enough workspace around the machine
- The machine can also work horizontally for extremely large diameters.



General Maintenance

The machine needs to be lubricating periodically for efficient working and longer to be lubricated periodically for efficient working and longer life. You can see the points of lubrication list below and a lubrication chart for periods of lubricated.

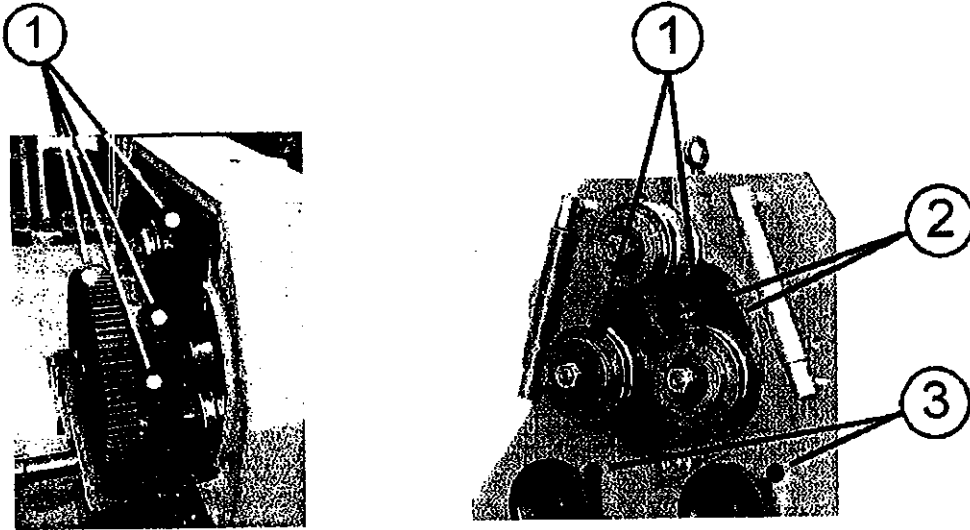

Attention :

The rolls of the machine must **NEVER** be greased or lubricated. Because, then the rolls will slip the material and will not bend. Always keep the rolls clean and free from grease or any lubricant. Also make sure that the material is free from grease and dirt.

These points must be greased periodically at least once a month or more if daily usage exceeds 8 hours a day.



Note:

That some one of these points are actually inside the machine cover and the front cover must be removed in order to reach them. Any standard commercial grease can be used for lubrication.

NUMBER	PERIOD	WHAT TO DO
1- Gears	Once a month	Grease
2- Roll shafts and bushing	Once a month	Grease
3- Roll housing	Every week	Grease
4- Grease channel	Every week	With SAE 30 or similar value oil

REDUCTION GEARBOX MAINTENANCE

The reduction gearbox of the machine backside of the machine and is maintenance free. Only you should control it periodically and tighten the bolts fixing it to motor and to the frame, if necessary.



PK 40 PARTS OF THE MAIN FRAME (1)

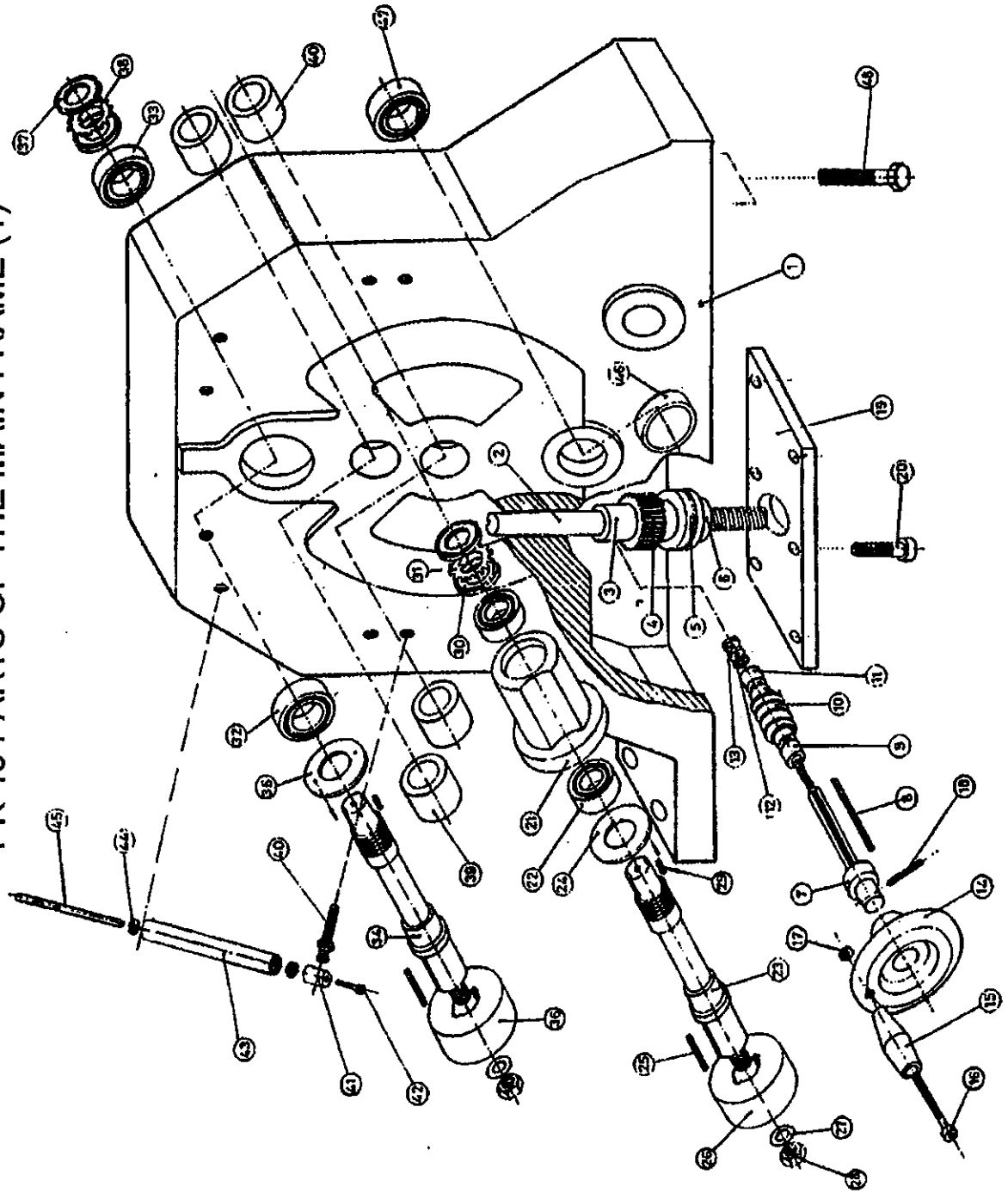



PARTS LIST 1 PK 40

1. Parts and Parts List of The Main Frame

Assembly No	Quantity	Parça tanımları	Part Identification	Brand
1	1	Gövde	Body	
2	2	Transport dişli mill	Lifting gear shaft	
3	2	Burç	Metal ring	
4	2	Sonsuz vida karşılık dişlisi	Worm gear	
5	2	51208 Eksenel rulman	51208 Axle ball bearing	
6	2	Burç	Metal ring	
7	2	Tahrik mili	Powering shaft	
8	2	6x60 kama	6x60 key	
9	2	Burç	Metal ring	
10	2	Sonsuz vida dişlisi	Worm gear	
11	2	Burç	Metal ring	
12	2	Rondela	Washer	
13	4	M12 Altıköşe somun	M12 Hex. Nut	
14	2	Döndürme tekeri	Revolve wheel	
15	2	Döndürme kolu	Revolve arm	
16	2	M10 Imbus	M10 Soc. Head Cap Bolt	
17	2	M10 Altıköşe somun	M10 Hex. Soc. Head Cap Bolt	
18	2	Ø 5x30 boru pim	Ø 5x30 dowel pin	
19	2	Alt kapak	Lower cover	
20	12	M8x35 Havşa başlı civata	M8x35 Bolt	
21	2	Ara yatak	Lower roll housing	
22	4	32008 Konik makaralı rulman	32008 Tapered roller bearing	
23	2	Alt vals tahrik mili	Lower roll's powering shaft	
24	2	Fiber kapak	Fibre cover	
25	6	10x85 kama	10x85 key	
26	2	Vals topu	Roll	
27	3	Rondela	Washer	
28	3	M24 altıköşe somun	M24 Hex. Nut	
29	6	10x35 Kama	10x35 key	
30	4	M40x15 çektime somunu	M40x15 pulling nut	
31	2	MB8 Emniyet rondelası	MB8 Safety washer	
32	1	32210 Konik makaralı rulman	32210 Tapered roller bearing	
33	1	32209 konik makaralı rulman	32209 Tapered roller bearing	
34	1	Üst vals tahrik mili	Top roll's powering shaft	
35	1	Fiber kapak	Sheet cover	
36	1	Vals topu	Roll	
37	2	M45X1,5 Çektime somunu	M40x1,5 pulling nut	
38	1	MB9 emniyet rondelası	MB9 Safety washer	
39	4	Grafit yatak	Graphite housing	
40	4	M20 Dayama bağlantı civatası	Guide joint's connecting bolt	
41	4	Dayama mafsalı	Guide joint	
42	4	M5x10 Imbus	M5x10 Soc. Head Cap Bolt	
43	4	Yan dayama mafsalı	Guide joint	
44	4	6001 Tek sıra bilyalı sabit rulman	6001 Single-row fixed ball bearing	
45	4	Yan dayama mili	Guide roll shaft	
46	1	6205-2Z Tek sıra bilyalı sabit rulman	205-2Z Single-row fixed ball bearing	
47	1	6205-2Z Tek sıra bilyalı sabit rulman	205-2Z Single-row fixed ball bearing	
48	4	M16x50 altıköşe başlı civata	M16x50 Hex. Soc. Head Cap Bolt	

PK 40 PARTS OF THE MAIN FRAME (2)

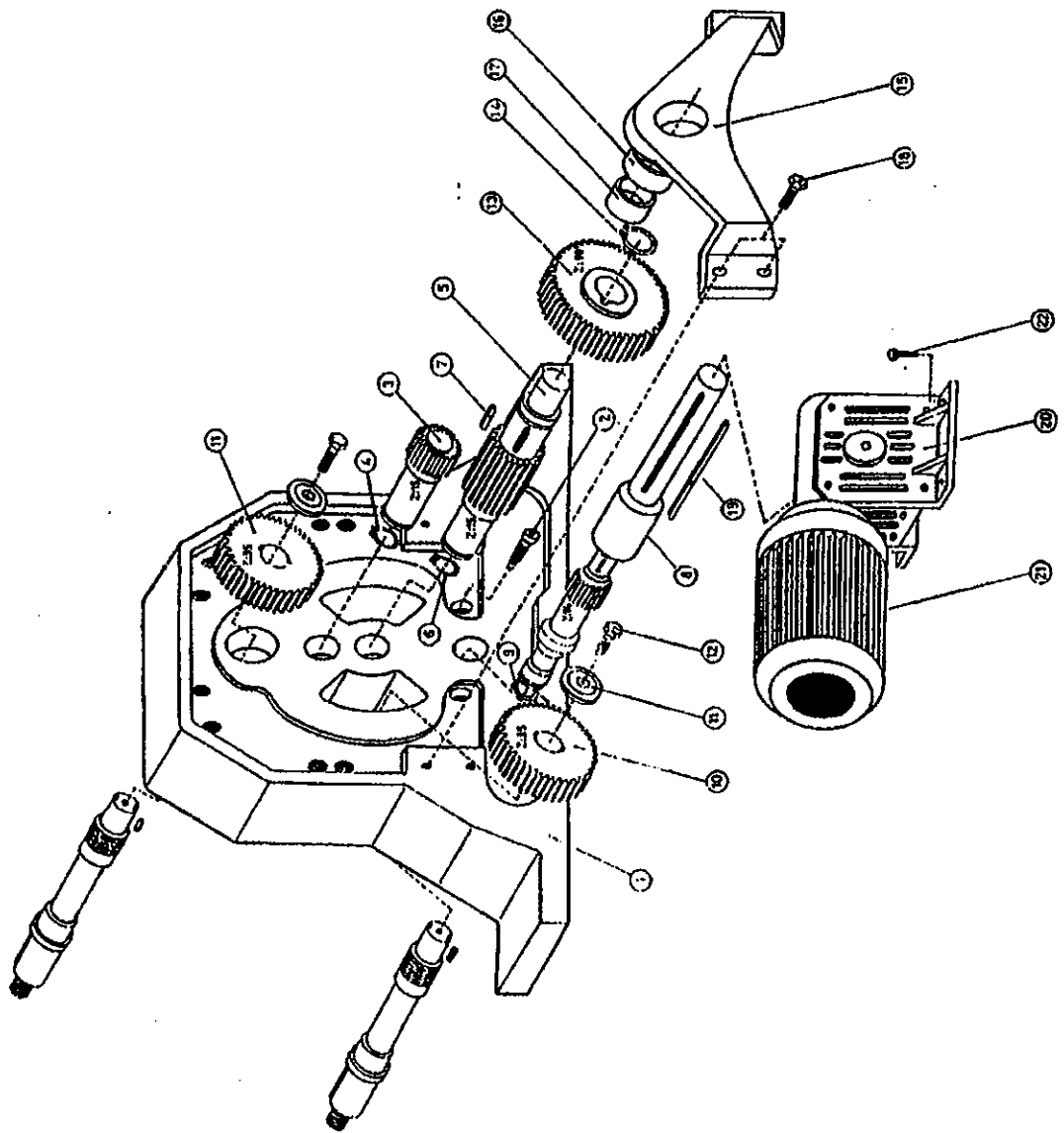

PARTS LIST 2

2. Parts and Parts List of The Main Frame

Assembly No	Quantity	Part Identification	Brand
1	1	Body	Şahinler
2	2	M10x45 Soc. Head Cap Bolt	OEM
3	1	Space pinion gear	Şahinler
4	1	Pinion gear's shaft steel ring	Şahinler
5	1	Motor shaft	Şahinler
6	1	Ø 45 retaining ring	Şahinler
7	1	12x32 Key	Şahinler
8	2	Lower gear shaft	Şahinler
9	2	Ø 25 retaining ring	OEM
10	3	Lower roll gear	Şahinler
11	3	Washer	Şahinler
12	3	M8x25 Hex. Soc. Head Cap Bolt	OEM
13	1	Central gear	Şahinler
14	1	Ø 48 retaining ring	OEM
15	1	Motor shaft's Guide housing	Şahinler
16	1	Metal ring	Şahinler
17	1	Graphite housing	Şahinler
18	4	M12x50 Housing fixing bolt	OEM
19	1	10x80 Key	Şahinler
20	1	Reductor	OEM
21	1	Motor	OEM
22	4	M10x35 Hex. Soc. Head Cap Bolt	OEM



SPECIAL ACCESSORIES FOR MODEL PK 40

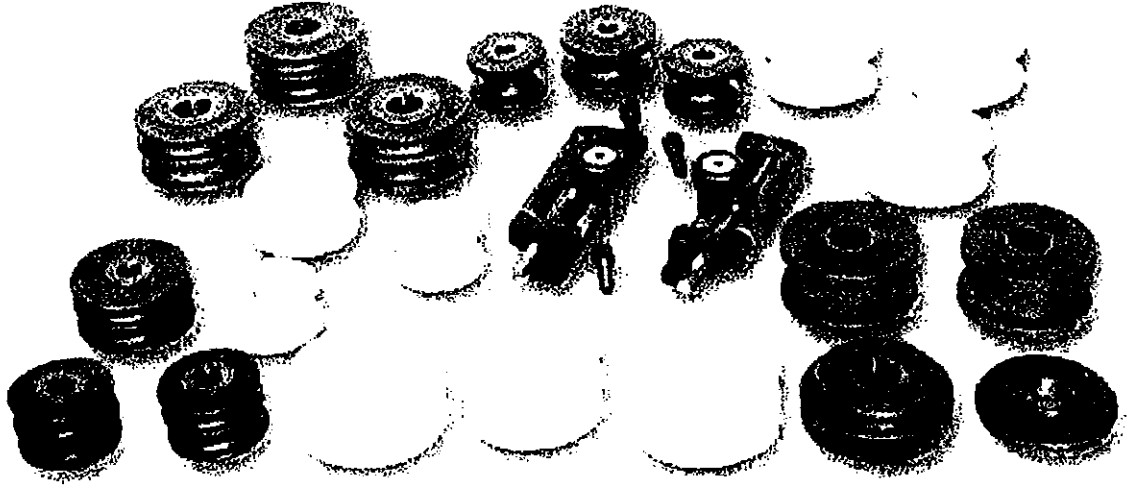

Various special rolls;

1. For bending
2. Aluminum profiles
3. Pipes, tubes
4. Hollow sections
5. Angle sections





ŞAHINLER METAL MAKİNA ENDÜSTRİ A. S.

izmir Yolu 22. km. Mumin Gencoğlu Caddesi
16285 BURSA/TÜRKİYE
Tel.: (+90 224)470 01 58 (PBX - 6 Hat/Line)
Fax.: (+90 224)470 07 70 - 470 09 05
www.sahinlermetal.com email: info@sahinlermetal.com

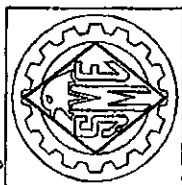

Customer :
Project name : PK - 40 PROFILE BENDING MACHINE
Drawing number : 08012004
Customer's address:

Manufacturer : SAHINLER METAL MAKİNA ENDÜSTRİ A. S.

File name (\EPLAN4\P): PK40400T
Drawn by : AHMET CETIN
Checked by : AHMET CETIN
Responsible for project : AHMET CETIN

Start Date : 03. Jan. 2004
Complete Date : 08. Jan. 2004
The Last Page : 4
Total page : 4

Date	06. Jan. 2004	PK - 40 (400V)	2
Drawn by	AHMET CETIN		
Checked by	AHMET CETIN		
Nur#	Original		
		MOTOR AND CONTROL GROUP	
		File number: PK40400T	2
		Drawing number: 08012004	
		Project name: PK40400T	1

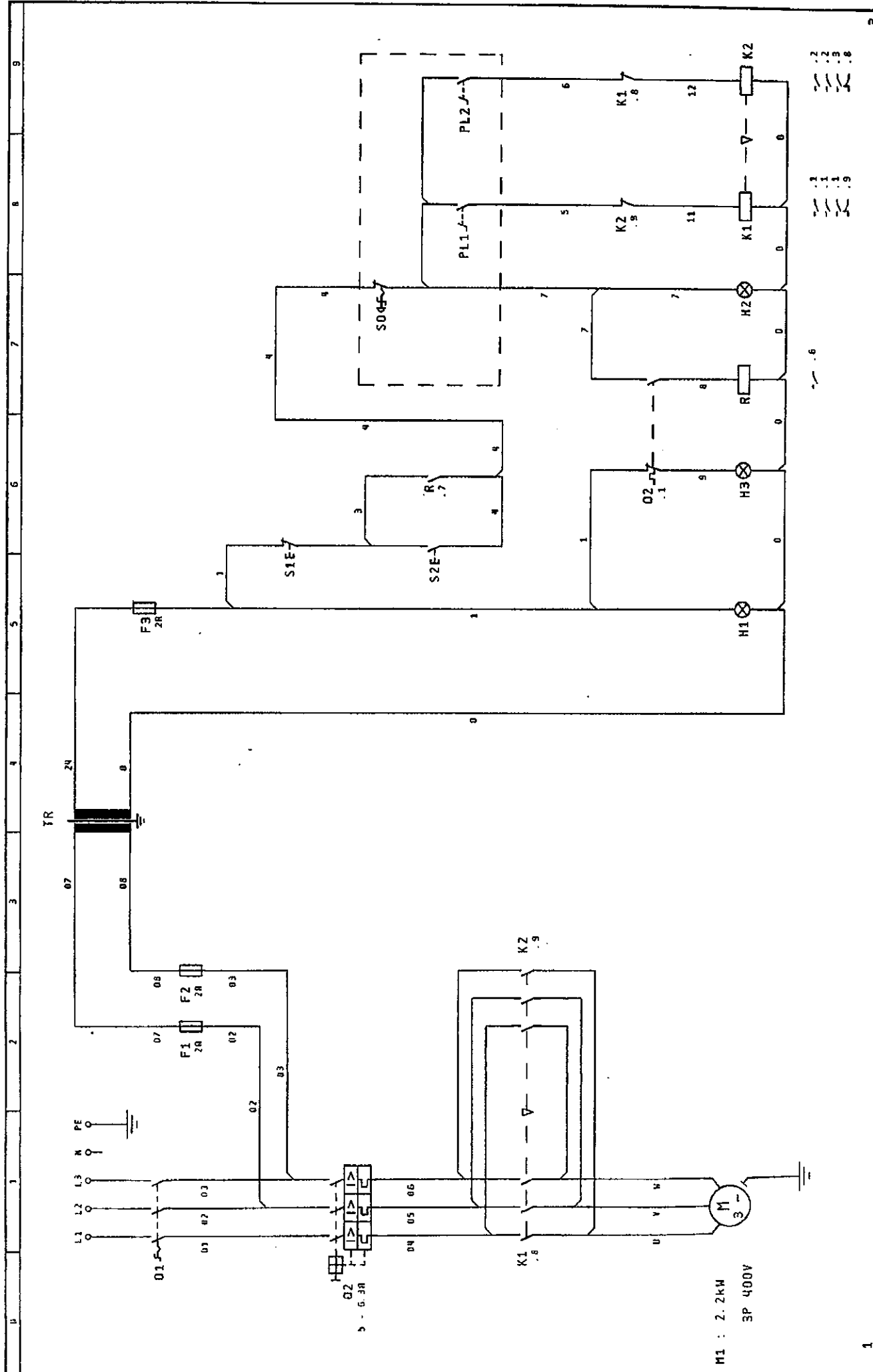

M1 : 2.2kW
 3P 400V

1
 2
 3
 6

1	08. Jan. 2004	PK - 40. (400V)	MOTOR AND CONTROL GROUP	Drawing number: 08012004	4 p
2	Drawn by	Checked by	Project name:	File number:	
3	Original			PK4000T	
4				PK4000T	

0 1 2 3 4 5 6 7 8 9

ELECTRICAL CABINET SCHEME

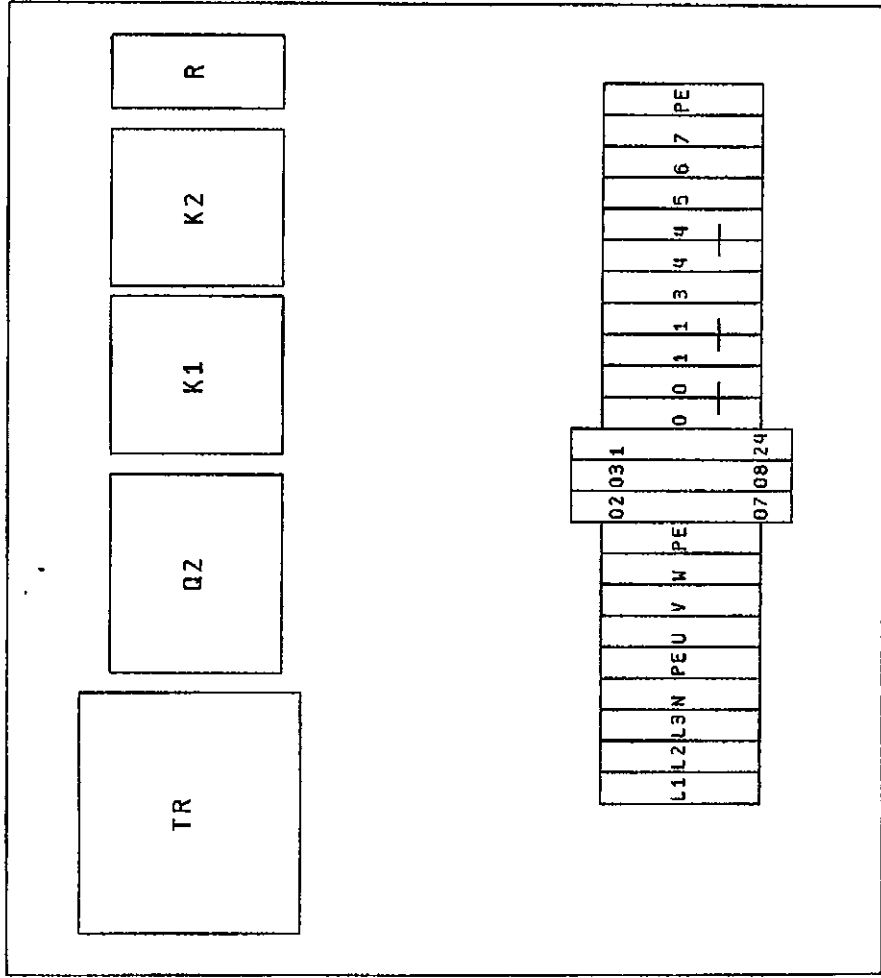

Date	08-Jan-2004	Project name:	PK40400T
Drawn by	ABNEL CEIIN	File number:	PK40400T
Checked by	ABNEL CEIIN	Project name:	PK40400T
Notes			
PK - 40 (400V)		ELECTRICAL CABINET SCHEME	
Original		 METAL MAKING INDUSTRIA S	

